

Design for Code Acceptance

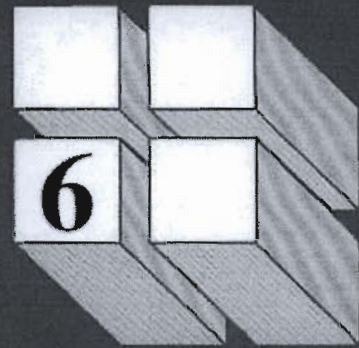

Prescriptive Residential Wood Deck Construction Guide

Based on the *2006 International Residential Code*

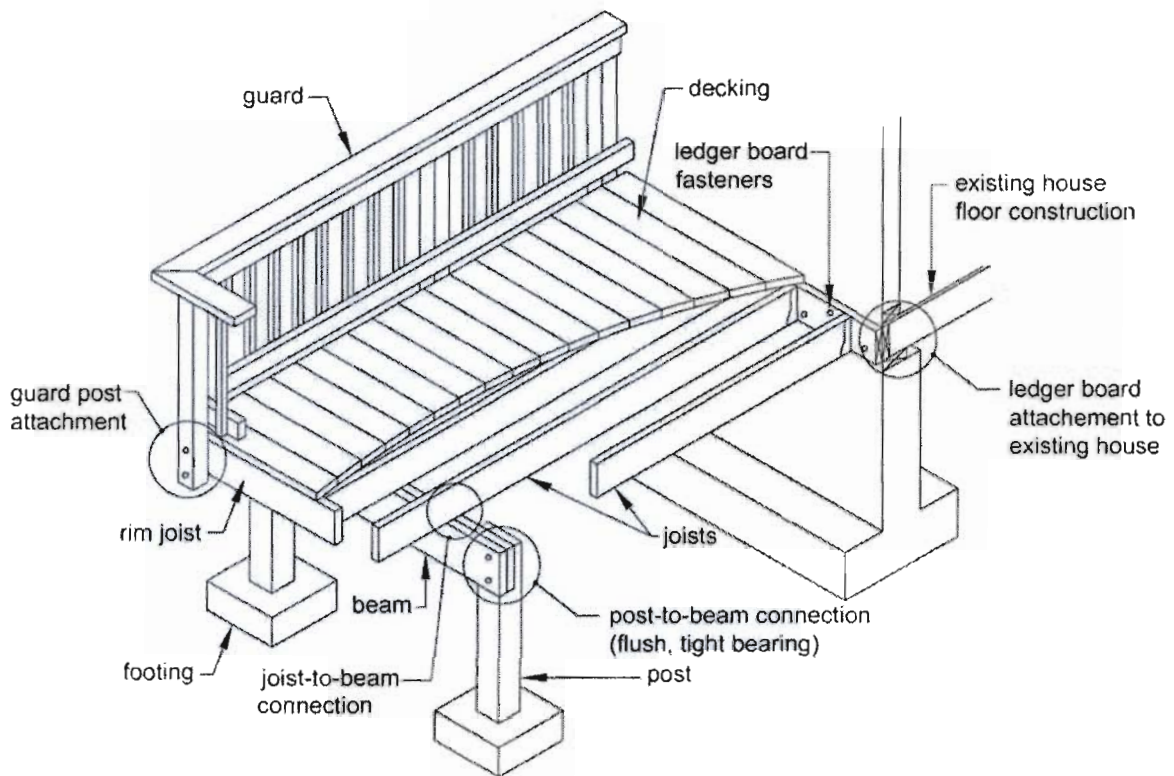

Where applicable, provisions and details contained in this document are based on the *International Residential Code (IRC)* [bracketed text references applicable sections of the *IRC*]. Prescriptive construction methods recommended meet or exceed minimum requirements of the *IRC*. Provisions that are not found in the *IRC* are recommended as good industry practice. Where differences exist between provisions of this document and the *IRC*, provisions of the *IRC* shall apply. This document is not intended to preclude the use of other construction methods or materials. All construction and materials must be approved by the authority having jurisdiction. Every effort has been made to reflect the language and intent of the *IRC*. However, no assurance can be given that designs and construction made in accordance with this document meet the requirements of any particular jurisdiction.

CONTENTS

MINIMUM REQUIREMENTS.....	2	PROHIBITED LEDGER ATTACHMENTS	12
DECKING REQUIREMENTS	3	LEDGER BOARD FASTENERS	12
JOIST SIZE.....	3	FREE-STANDING DECKS.....	14
BEAM SIZE & ASSEMBLY REQUIREMENTS	5	DECK STABILITY	14
DECK FRAMING PLAN	6	GUARD REQUIREMENTS	15
JOIST-TO-BEAM CONNECTION	7	GUARD POST ATTACHMENTS	16
JOIST HANGERS	7	STAIR REQUIREMENTS.....	17
POST REQUIREMENTS	7	STAIR HANDRAIL REQUIREMENTS	18
RIM JOIST REQUIREMENTS.....	8	STAIR FOOTING REQUIREMENTS	19
FOOTINGS.....	9	STAIR LIGHTING REQUIREMENTS.....	19
LEDGER ATTACHMENT REQUIREMENTS.....	10	FRAMING AT CHIMNEY OR BAY WINDOW	19

MINIMUM REQUIREMENTS

- This document applies to single level residential wood decks only.
- All lumber shall be identified by the grade mark of, or certificate of inspection issued by, an approved lumber grading or inspection bureau or agency (www.alsc.org). All lumber shall be a naturally durable species (such as Redwood or Western Cedars) or be pressure-treated with an approved process and preservative in accordance with American Wood Protection Association standards (Table 1) [R319.1 and R320.1]. All lumber in contact with the ground shall be approved preservative treated wood suitable for ground contact. [R319.1.2]
- All nails shall meet the requirements of *ASTM F 1667*. Wood screws shall meet the requirements of *ANSI/ASME B18.6.1*. Bolts and lag screws shall meet the requirements of *ANSI/ASME B18.2.1*.
- To resist corrosion, the following is required [R319.3]:
 - All screws, bolts, and nails for use with preservative treated wood shall be hot-dipped galvanized, stainless steel, silicon bronze or copper. Fasteners to be hot-dipped galvanized shall meet the requirements of *ASTM A 153, Standard Specification for Zinc Coating (Hot-Dip) on Iron and Steel Hardware*, Class D for fasteners $\frac{3}{8}$ " in diameter and smaller or Class C for fasteners with diameters over $\frac{3}{8}$ ".
 - Fasteners other than nails and timber rivets shall be permitted to be of mechanically deposited zinc-coated steel with coating weights in accordance with *ASTM B 695*, Class 55, minimum.
 - All hardware (joist hangers, cast-in-place post anchors, etc.) shall be galvanized or shall be stainless steel. Hardware to be hot-dipped prior to fabrication shall meet *ASTM A 653, Standard Specification for Steel Sheet, Zinc-Coated (Galvanized) or Zinc-Iron Alloy-Coated (Galvannealed) by the Hot-Dip Process*, G-185 coating. Hardware to be hot-dipped galvanized after fabrication shall meet *ASTM A123, Specification for Zinc (Hot-Dip Galvanized) Coatings on Iron and Steel Products*.
 - Fasteners and connectors exposed to, and located within 300 feet of, a salt water shoreline shall be stainless steel grade 304 or 316.
 - Other coated or non-ferrous fasteners or hardware shall be as approved by the authority having jurisdiction.
- Decks supporting hot tubs are beyond the scope of this document.
- This document does not apply to decks which will experience snow loads, snow drift loads, or sliding snow loads that exceed 40 psf. This document does not address lateral loads on decks such as wind or seismic.
- Flashing shall be corrosion-resistant metal of minimum nominal 0.019-inch thickness or approved non-metallic material [R703.8].
- Decks shall not be used or occupied until final inspection and approval is obtained.
- This document is not intended to preclude the use of other construction methods or materials not shown herein.



Cumberland County Building Inspections
PO Box 110
Cumberland, VA 23040
Phone: 804-492-9114
Fax: 804-492-9224

Decks: Residential Use Only

We will allow the use of 5/4 (five quarter) boards when building decks, maximum floor span of 2ft on center.

The use of 5/4 (five quarter) boards will also be allowed on step treads that are built on stringers not spanning more than 12" on center.

*For Southern pine deck board to be used, the product needs to be grade marked by an accredited lumber grading agency (such as TP or SPIB) and the stamp must relay either a "premium" or "standard" grade mark. The maximum span of the individual board should be 24" and shall be a two span minimum condition. *

Table 1. Common preservative treatments and retention levels (pcf) for sawn lumber in ground contact.^a

Species	ACQ-B	ACQ-C	ACQ-D	CA-B	CuN-W
Southern Pine	0.40	0.40	0.40	0.21	0.11
Douglas Fir-Larch	0.40	0.40	NR	0.21	0.11
Hem-Fir	0.40	0.40	0.40	0.21	0.11
Ponderosa Pine	0.40	0.40	0.40	0.21	0.11
Red Pine	0.40	0.40	0.40	0.21	0.11
Spruce-Pine-Fir	NR	0.40	NR	NR	NR
Redwood	NR	NR	NR	NR	NR

^a Preservatives and retentions listed in Table 1 are based on the American Wood Protection Association (AWPA) *Book of Standards*. NR = Treatments Not Recommended.

DECKING REQUIREMENTS

All decking material shall be composed of dimension lumber (2" nominal thickness) or span rated decking in accordance with the American Lumber Standard Committee *Policy for Evaluation of Recommended Spans for Span Rated Decking Products (November 5, 2004)*. Attach decking to each joist with 2-8d threaded nails or 2-#8 screws. Space decking boards approximately 1/8" apart. See Figure 11 for decking connection requirements at the rim joist. Decking may be placed from an angle perpendicular to the joists to an angle of 45 degrees to the joists. Each segment of decking must bear on a minimum of 4 joists.

Decking not meeting the above requirements may be substituted when the product has been approved by the authority having jurisdiction.

*2A

JOIST SIZE

The span of a joist is measured from the centerline of bearing at one end of the joist to the centerline of bearing at the other end of the joist and does not include the length of the overhangs. Use Table 2 to determine joist span based on lumber size and joist spacing. See Figure 1 and Figure 2 for joist span types.

Table 2. Maximum Joist Spans (L_J)¹

Species	Size	Joist Spacing (o.c.)		
		12"	16"	24"
Southern Pine	2x8	10' - 6"	10' - 6"	10' - 2"
	2x10	15' - 2"	15' - 2"	13' - 1"
	2x12	18' - 0"	18' - 0"	15' - 5"
Douglas Fir-Larch, Hem-Fir, SPF ²	2x8	9' - 3"	9' - 3"	9' - 1"
	2x10	13' - 4"	13' - 4"	11' - 1"
	2x12	17' - 10"	15' - 9"	12' - 10"
Redwood, Western Cedars, Ponderosa Pine ³ , Red Pine ³	2x8	8' - 4"	8' - 4"	8' - 4"
	2x10	12' - 0"	12' - 0"	10' - 7"
	2x12	16' - 1"	15' - 1"	12' - 3"

1. Assumes 40 psf live load, 10 psf dead load, L/180 cantilever deflection with 230 lb point load, No. 2 grade, and wet service conditions. See span calculator at www.awc.org for simple span conditions without cantilevers.

2. Incising assumed for refractory species including Douglas fir-larch, hem-fir, and spruce-pine-fir.

3. Design values based on northern species with no incising assumed.

Figure 1A: Joist Span – Deck Attached at House and Bearing Over Beam

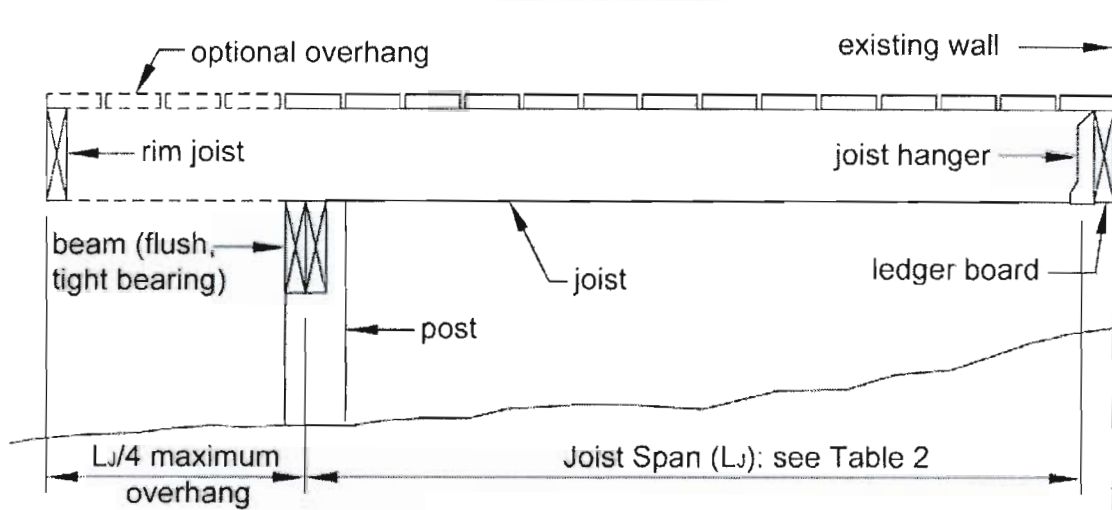

Figure 1B: Joist Span – Joists Attached at House and to Side of Beam

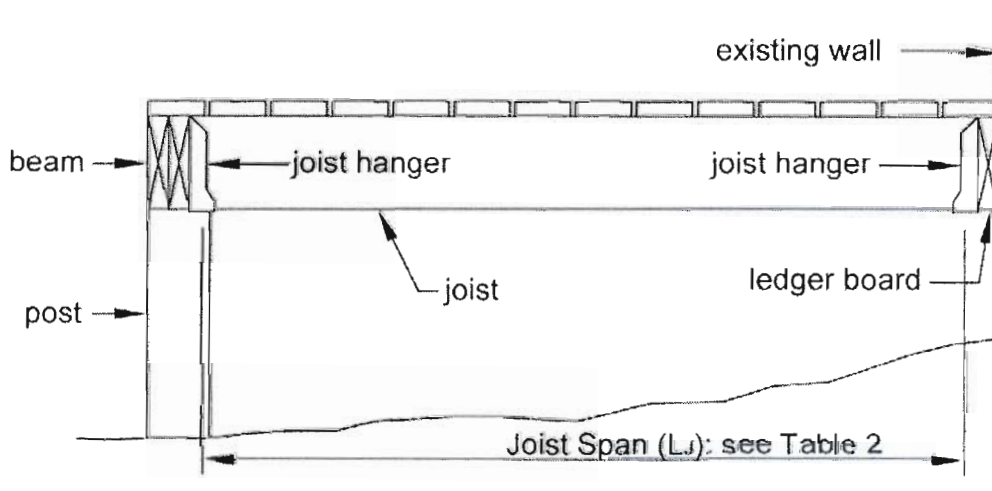
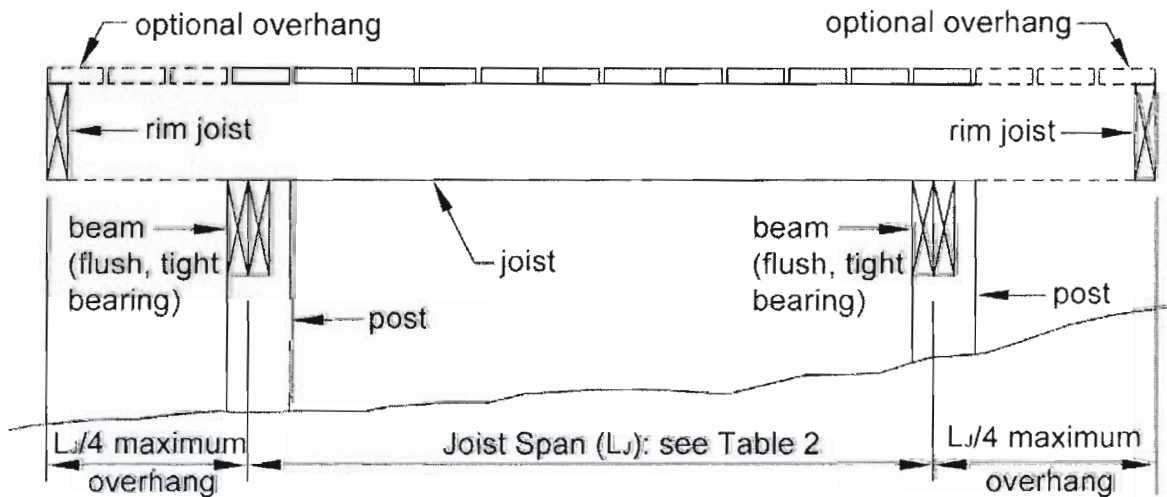

Figure 2: Joist Span – Free Standing Deck



BEAM SIZE & ASSEMBLY REQUIREMENTS

Deck beam spans shall be in accordance with Table 3 and can extend past the post centerline up to $L_B/4$ as shown in Figure 3. Joists may bear on the beam and extend past the beam centerline up to $L_J/4$ as shown in Figures 1A and 2, or the joists may attach to the side of the beam with joist hangers as shown in Figure 1B

(however, joists shall not be attached to opposite sides of the same beam). See JOIST-TO-BEAM CONNECTION details, Figure 6.

Where multiple 2x members are used, the deck's beam is assembled by attaching the members identified in Table 3 in accordance with Figure 4. [R602.3(1)]

Table 3. Deck Beam Spans (L_B)¹

Species	Size	Joist Spans (L_J) Less Than or Equal to:						
		6'	8'	10'	12'	14'	16'	18'
Southern Pine	2-2x6	7' - 1"	6' - 2"	5' - 6"	5' - 0"	4' - 8"	4' - 4"	4' - 1"
	2-2x8	9' - 2"	7' - 11"	7' - 1"	6' - 6"	6' - 0"	5' - 7"	5' - 3"
	2-2x10	11' - 10"	10' - 3"	9' - 2"	8' - 5"	7' - 9"	7' - 3"	6' - 10"
	2-2x12	13' - 11"	12' - 0"	10' - 9"	9' - 10"	9' - 1"	8' - 6"	8' - 0"
	3-2x6	8' - 7"	7' - 8"	6' - 11"	6' - 3"	5' - 10"	5' - 5"	5' - 2"
	3-2x8	11' - 4"	9' - 11"	8' - 11"	8' - 1"	7' - 6"	7' - 0"	6' - 7"
	3-2x10	14' - 5"	12' - 10"	11' - 6"	10' - 6"	9' - 9"	9' - 1"	8' - 7"
	3-2x12	17' - 5"	15' - 1"	13' - 6"	12' - 4"	11' - 5"	10' - 8"	10' - 1"
	Douglas Fir-Larch ² , Hem-Fir ² , SPF ² , Redwood, Western Cedars, Ponderosa Pine ³ , Red Pine ³	3x6 or 2-2x6	5' - 5"	4' - 8"	4' - 2"	3' - 10"	3' - 6"	3' - 1"
3x8 or 2-2x8		6' - 10"	5' - 11"	5' - 4"	4' - 10"	4' - 6"	4' - 1"	3' - 8"
3x10 or 2-2x10		8' - 4"	7' - 3"	6' - 6"	5' - 11"	5' - 6"	5' - 1"	4' - 8"
3x12 or 2-2x12		9' - 8"	8' - 5"	7' - 6"	6' - 10"	6' - 4"	5' - 11"	5' - 7"
4x6		6' - 5"	5' - 6"	4' - 11"	4' - 6"	4' - 2"	3' - 11"	3' - 8"
4x8		8' - 5"	7' - 3"	6' - 6"	5' - 11"	5' - 6"	5' - 2"	4' - 10"
4x10		9' - 11"	8' - 7"	7' - 8"	7' - 0"	6' - 6"	6' - 1"	5' - 8"
4x12		11' - 5"	9' - 11"	8' - 10"	8' - 1"	7' - 6"	7' - 0"	6' - 7"
3-2x6		7' - 4"	6' - 8"	6' - 0"	5' - 6"	5' - 1"	4' - 9"	4' - 6"
3-2x8		9' - 8"	8' - 6"	7' - 7"	6' - 11"	6' - 5"	6' - 0"	5' - 8"
3-2x10	12' - 0"	10' - 5"	9' - 4"	8' - 6"	7' - 10"	7' - 4"	6' - 11"	
3-2x12	13' - 11"	12' - 1"	10' - 9"	9' - 10"	9' - 1"	8' - 6"	8' - 1"	

1. Assumes 40 psf live load, 10 psf dead load, L/360 simple span beam deflection limit, L/180 cantilever deflection limit, No. 2 grade, and wet service conditions.
2. Incising assumed for refractory species including Douglas fir-larch, hem-fir, and spruce-pine-fir.
3. Design values based on northern species with no incising assumed.

Figure 3: Beam Span Types

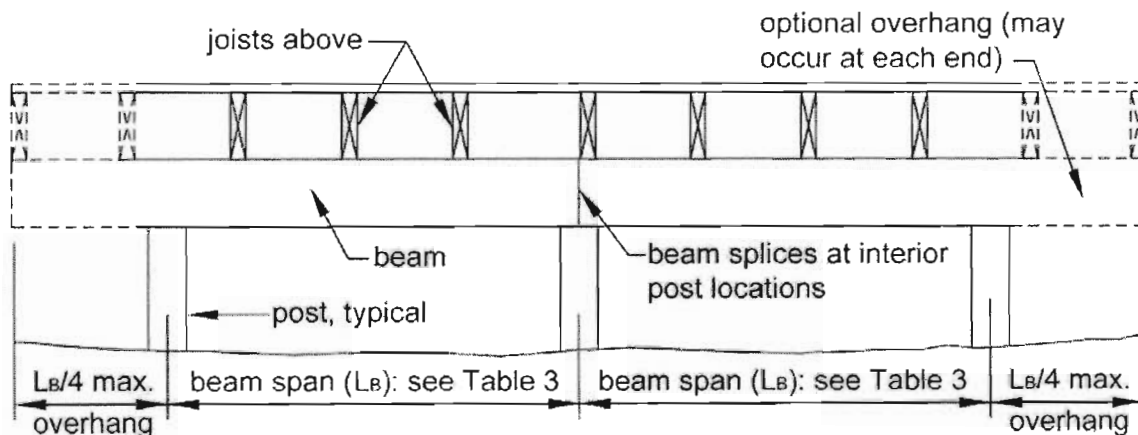
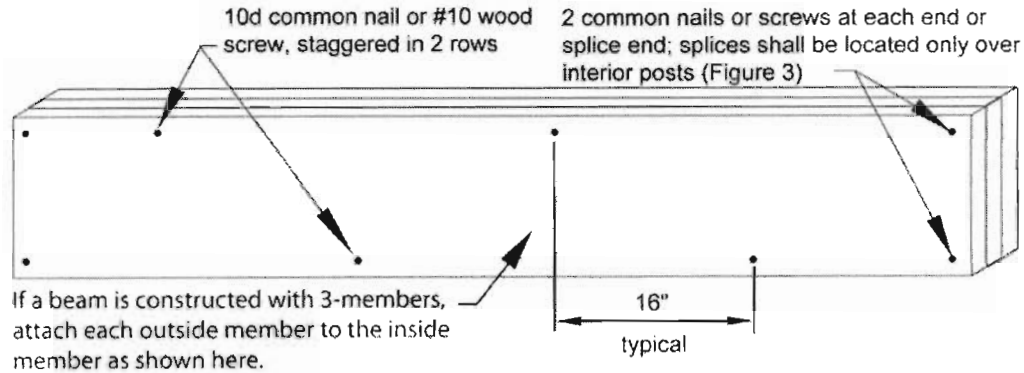

Figure 4: Beam Assembly Details



DECK FRAMING PLAN

A framing plan shows the joist and beam layout; the location of the ledger board, posts, and footings, and the type, size, and spacing of the ledger board fasteners. See Figure 5 for an example of a typical deck framing plan.

Figure 5: Typical Deck Framing Plan

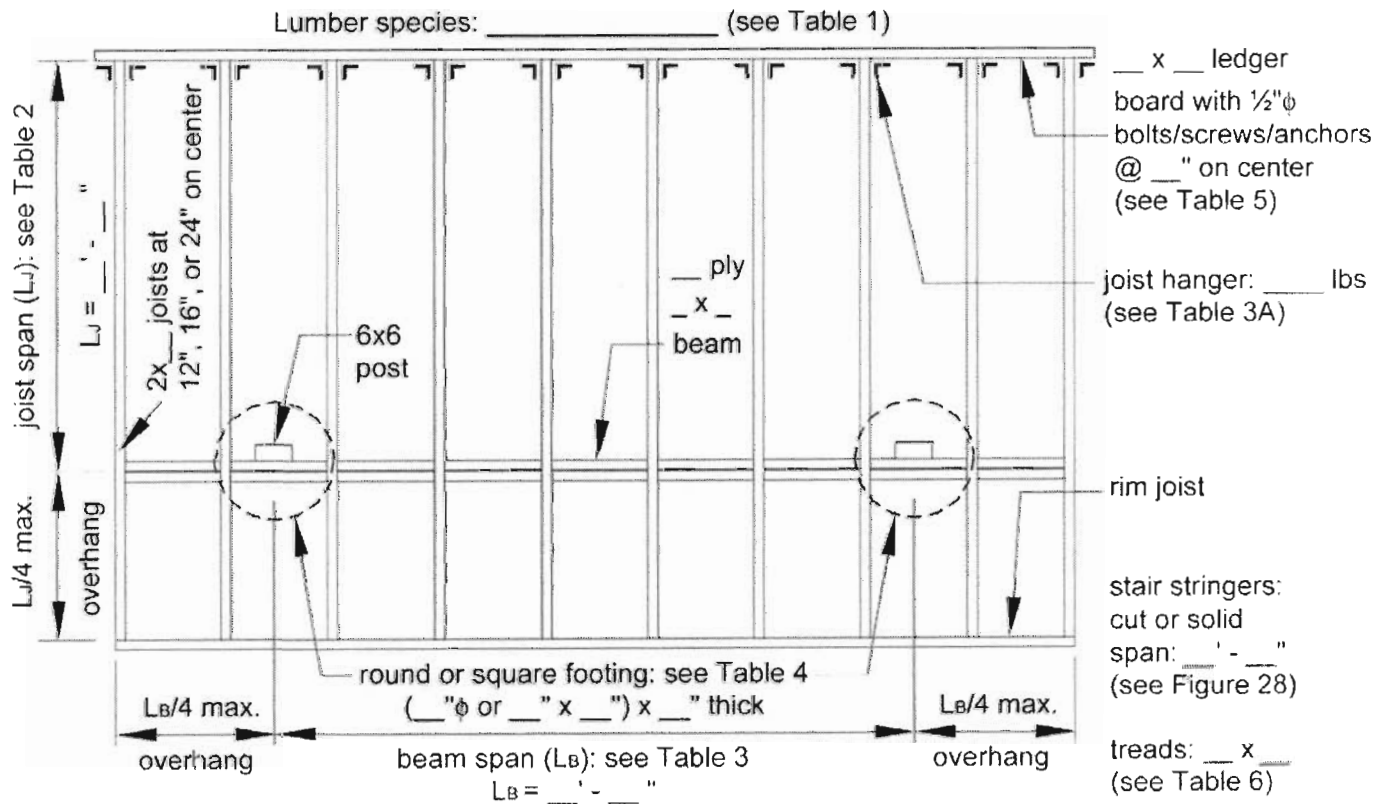

JOIST-TO-BEAM CONNECTION

Each joist shall be attached to the beam as shown in Figure 6. Joists may bear on and overhang past the beam a maximum of $L_j/4$. Use Option 1 or Option 2 to attach the joist to the beam. Option 1 shall only be used if the deck is attached to the house with a ledger (see LEDGER ATTACHMENT REQUIREMENTS) or as shown in Figure 23. Mechanical fasteners or hurricane

clips used as shown in Option 2 must have a minimum capacity of 100 lbs in both uplift and lateral load directions. Joists may also attach to the side of the beam with joist hangers per Option 3 (however, joists shall not be attached to opposite sides of the same beam). See JOIST HANGERS for more information. Hangers, clips, and mechanical fasteners shall be galvanized (see MINIMUM REQUIREMENTS).

Figure 6: Joist-to-Beam Detail

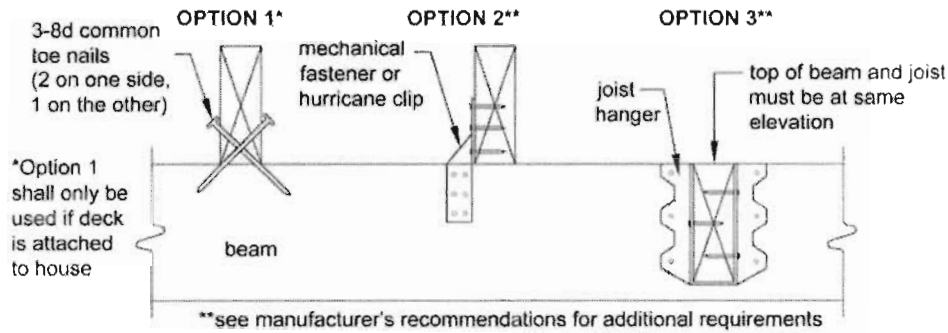

JOIST HANGERS

Joist hangers, as shown in Figure 7, shall each have a minimum download capacity in accordance with Table 3A. The joist hanger shall be selected from an approved manufacturer's product data based on the dimensions of the joist or header it is carrying. Joist hangers shall be galvanized (see MINIMUM REQUIREMENTS).

Use joist hangers with inside flanges when clearances to the edge of the beam or ledger board dictate. **Do not use clip angles or brackets to support joists.**

Figure 7: Typical Joist Hangers

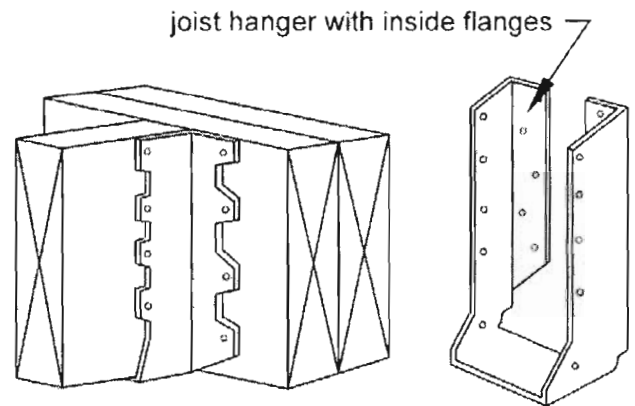

Table 3A: Joist Hanger Download Capacity

Joist Size	Minimum Capacity, lbs
2x8	600
2x10	700
2x12	800

POST REQUIREMENTS [R407]

All deck post sizes shall be 6x6 (nominal) or larger, and the maximum height shall be 14'-0" measured to the underside of the beam. Posts shall be centered on footings. Cut ends of posts shall be field treated with an approved preservative (such as copper naphthenate) [R402.1.2]. The beam shall be attached to the post by

notching the 6x6 as shown in Figure 8 or by providing an approved post cap to connect the beam and post as shown in Figure 10. All 3-ply beams shall be connected to the post by a post cap. All thru-bolts shall have washers at the bolt head and nut. Attachment of the beam to the side of the post without notching is prohibited (see Figure 9).

Figure 8: Post-to-Beam Attachment Requirements

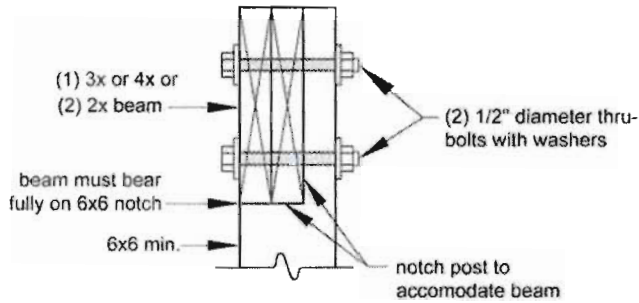
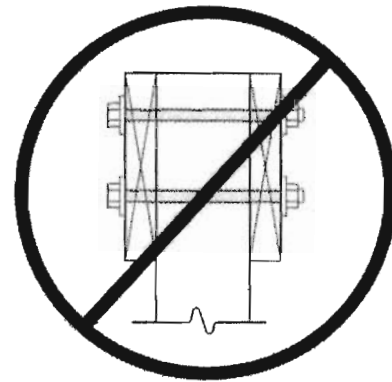

Figure 9: Prohibited Post-to-Beam Attachment Condition



RIM JOIST REQUIREMENTS

Attach a continuous rim joist to the ends of joists as shown in Figure 11. Attach decking to the rim joist as shown in Figure 11. For more decking attachment requirements, see DECKING REQUIREMENTS.

Figure 10: Alternate Approved Post-to-Beam Post Cap Attachment

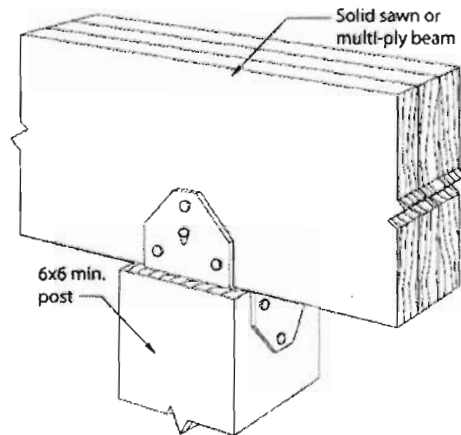
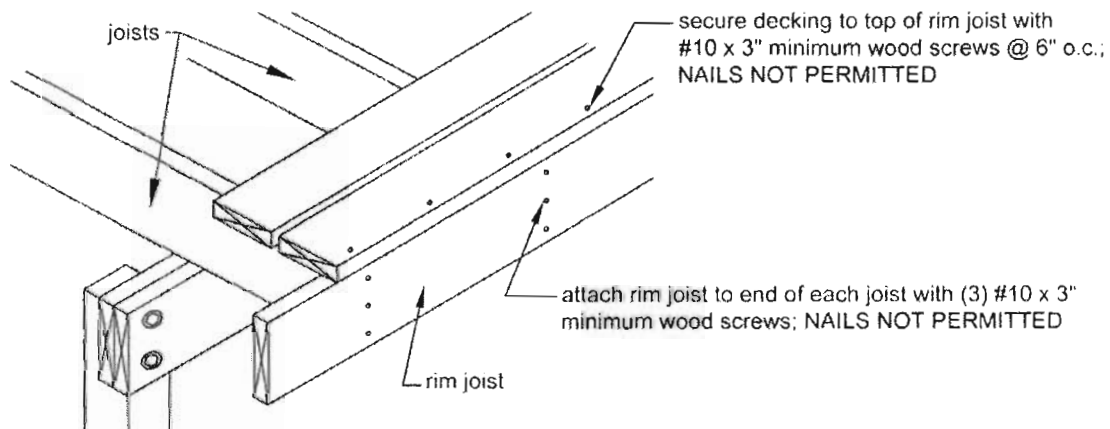

Figure 11: Rim Joist Connection Details



FOOTINGS [R403]

See Figure 12 and Table 4 for footing size, footing thickness, and post attachment options and requirements. All footings shall bear on solid ground and shall be placed at least 12 inches below the undisturbed ground surface or below the frost line, whichever is deeper; bearing conditions shall be verified in the field by the building official prior to placement of concrete. Where the building official determines that in-place soils with an allowable bearing capacity of less than 1,500 psf are likely to be present at the site, the allowable bearing capacity shall be determined by a soils investigation. **DECK FOOTINGS CLOSER THAN 5'-0" TO AN EXISTING EXTERIOR HOUSE WALL MUST BEAR AT THE SAME ELEVATION AS THE FOOTING OF THE EXISTING HOUSE FOUNDATION.**

Do not construct footings over utility lines or enclosed meters. Call the local utilities before digging.

Pre-manufactured post anchors shall be galvanized. See MINIMUM REQUIREMENTS.

Table 4. Footing Sizes²

Beam Span, L _B	Joist Span, L _J	Round ¹ Footing Diameter	Footing Thickness ³
6'	<10'	15"	6"
	<14'	17"	6"
	<18'	20"	7"
8'	<10'	17"	6"
	<14'	20"	8"
	<18'	23"	9"
10'	<10'	19"	7"
	<14'	22"	9"
	<18'	25"	10"
12'	<10'	21"	8"
	<14'	24"	10"
	<18'	28"	11"
14'	<10'	22"	9"
	<14'	26"	11"
	<18'	30"	12"
16'	<10'	24"	9"
	<14'	28"	12"
	<18'	32"	13"
18'	<10'	25"	10"
	<14'	30"	12"
	<18'	34"	14"

1. Square footings are permitted to have widths 2" less than the given diameter of round footings.
2. Assumes 1,500 psf soil bearing capacity.
3. Assumes 2,500 psi compressive strength of concrete. Coordinate footing thickness with post base and anchor requirements.

Figure 12: Typical Footing Options

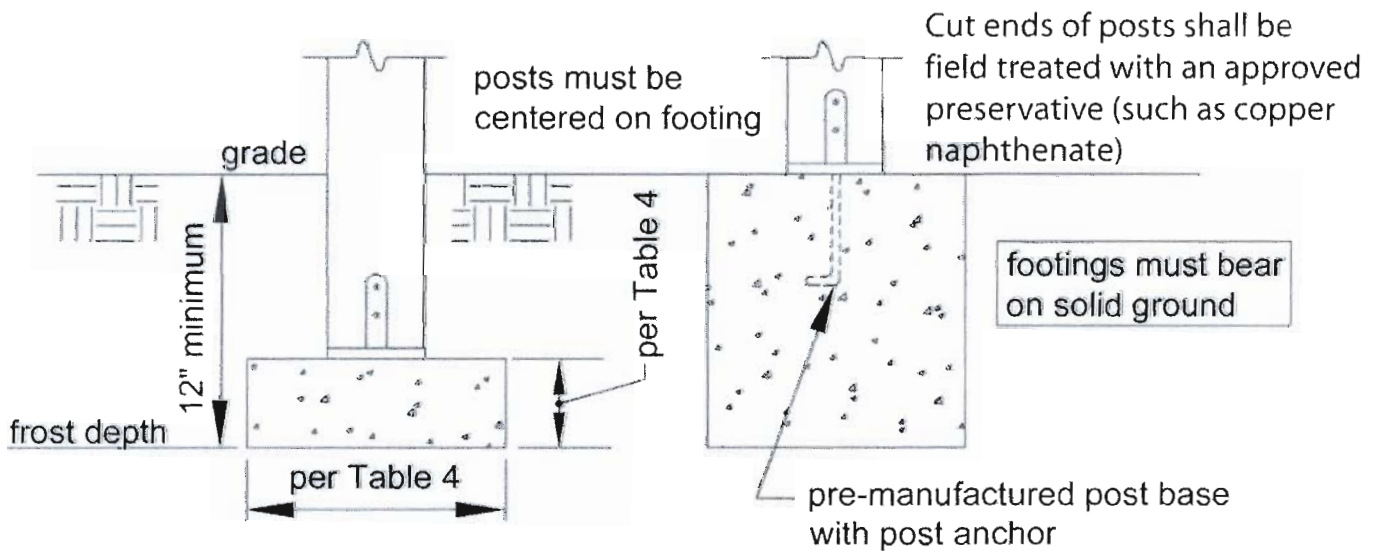

LEDGER ATTACHMENT REQUIREMENTS**[R502.2.1]**

GENERAL: Attach the ledger board, which shall be equal to or greater than the deck joist depth, but less than or equal to the rim joist depth, to the existing exterior wall in accordance with Figure 14 through Figure 16. When attachments are made to the existing house band joist, the band joist shall be capable of supporting the new deck. If this cannot be verified or conditions at the existing house differ from the details herein, then either a free-standing deck or full plan submission is required. See FREE-STANDING DECKS.

SIDING AND FLASHING: House siding, or the exterior finish system, must be removed prior to installation of the ledger board. Approved corrosion resistant flashing is required at any ledger board connection to a wall of wood framed construction (see MINIMUM REQUIREMENTS). See Figure 14 for continuous flashing with drip edge. The threshold shall be carefully flashed and caulked to prevent water intrusion due to splash from the deck or melting snow and ice.

MANUFACTURED WOOD I-JOIST: The term “I-Joist” denotes manufactured wood “I” joists (see Figure 13A). Many new homes constructed with wood I-joists include 1” or thicker engineered wood products (EWP) –

such as oriented strand board (OSB) or structural composite lumber (SCL) including laminated veneer lumber (LVL) – as band joists (or rim boards) that can support the attachment of a deck (see Figure 14). However, some older homes might be constructed with band boards that are too thin (less than 1”) to support a deck. In such cases, a free-standing deck or a full plan submission is required.

MANUFACTURED WOOD TRUSS: A metal plate connected wood truss (MPCWT) is an engineered, prefabricated structural component designed for each specific application. MPCWT’s used in residential floors are often installed with a 2x4 lumber “ribbon” at the ends of the trusses (see Figure 13B), the purpose of which is to tie the ends of the trusses together. The ribbon board, by itself, is not intended to support the deck ledger and deck. Installing residential decks when the floor system for the house uses MPCWT requires a standard detail provided by the truss designer, a free-standing deck, or a full plan submission. Refer to the WTCA Technical Note – *Attachment of Residential Decks to Wood Truss Floor Systems* for special blocking details and attachment requirements (www.sbcindustry.com).

Figure 13A: Wood I-Joist Profile

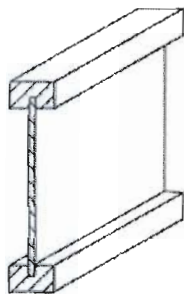

Figure 13B: Metal Plate Connected (MPC) Wood Floor Trusses with a 2x4 Lumber “Ribbon” at the Ends of the Trusses

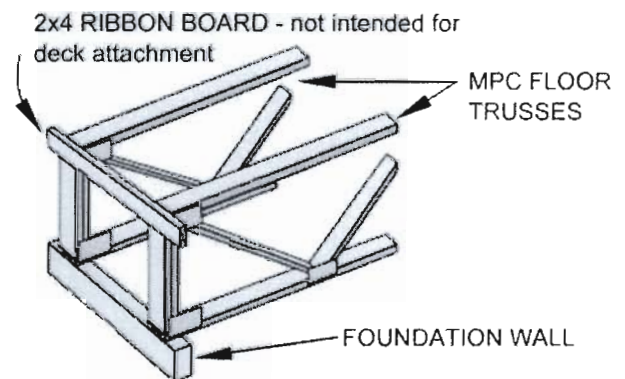

Figure 14: General Attachment of Ledger Board to Band Joist or Rim Board

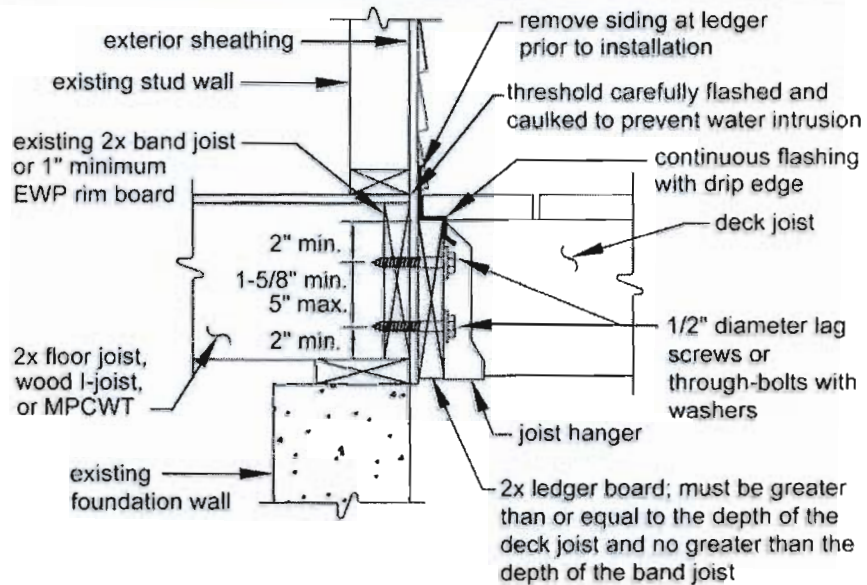

Figure 15: Attachment of Ledger Board to Foundation Wall (Concrete or Solid Masonry)

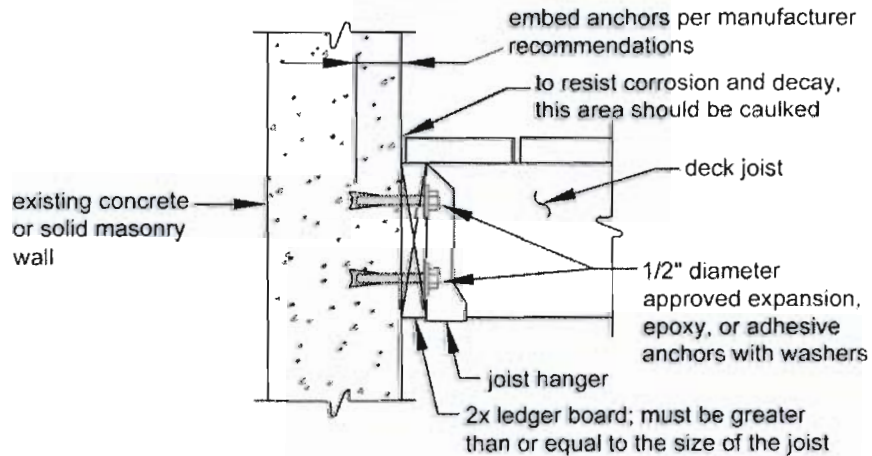
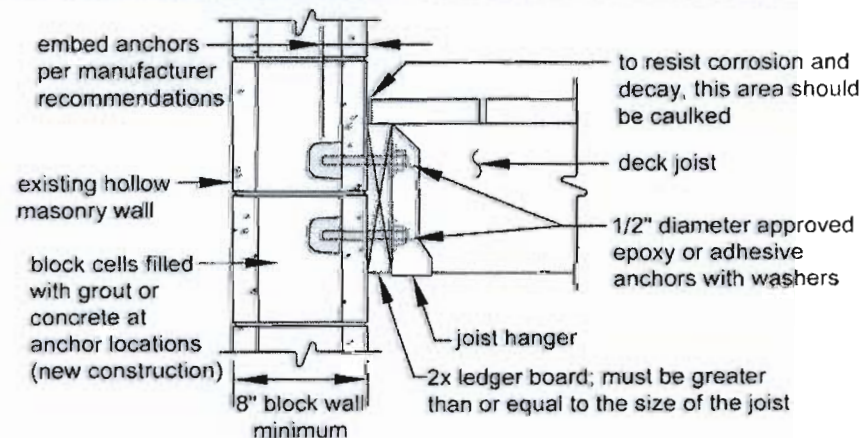

Figure 16: Attachment of Ledger Board to Foundation Wall (Hollow Masonry)



PROHIBITED LEDGER ATTACHMENTS

Attachments to exterior veneers (brick, masonry, stone) and to cantilevered floor overhangs or bay windows are prohibited (see Figures 17 and 18). In such cases the

deck shall be free-standing (see FREE-STANDING DECKS).

Figure 17: No Attachment to or Through Exterior Veneers (Brick, Masonry, Stone)

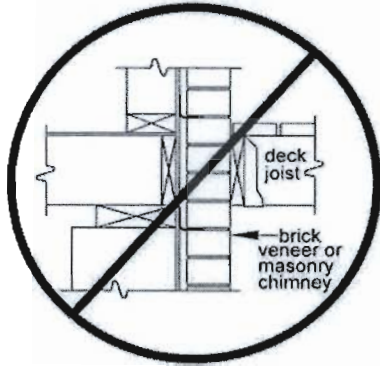

Figure 18: No Attachment to House Overhang



31. Add Section R502.2.2.1 to read:

R502.2.2.1 Deck ledger connection to band joist. For residential applications and a total design load of 50 psf, the connection between a pressure preservative treated southern pine (or approved decay-resistant species) deck ledger and a two-inch nominal band joist bearing on a sill plate or wall plate shall be constructed with 1/2-inch lag screws or bolts with washers per Table R502.2.2.1.

32. Add Table R502.2.2.1 to read:

**TABLE R502.2.2.1
FASTENER SPACING FOR A RESIDENTIAL SOUTHERN PINE DECK LEDGER
AND A 2-INCH NOMINAL SOLID-SAWN BAND JOIST (50 PSF TOTAL LOAD):^c**

JOIST SPAN (ft)	6' AND LESS	6'-1" TO 8'	8'-1" TO 10'	10'-1" TO 12'	12'-1" TO 14'	14'-1" TO 16'	16'-1" TO 18'
On-Center Spacing of Fasteners ^{d,e}							
1/2" x 4" Lag Screw ^{a,b}	30	23	18	15	13	11	10
1/2" Bolt with washers	36	36	34	29	24	21	19

- a. The maximum gap between the face of the ledger board and face of the house band joist shall be 1/2 inch.
- b. The tip of the lag screw shall fully extend beyond the inside face of the band joist.
- c. Ledgers shall be flashed to prevent water from contacting the house band joist.
- d. Lag screws and bolts shall be staggered as set out in Section R502.2.2.1.1.
- e. Deck ledger shall be 2x8 PPT No. 2 Southern Pine (minimum) or other approved method and material as established by standard engineering practice.

33. Add Section R502.2.2.1.1 to read:

R502.2.2.1.1 Placement of lag screws or bolts in residential deck ledgers. The lag screws or bolts shall be placed two inches in from the bottom or top of the deck ledgers and two inches in from the ends. The lag screws or bolts shall be staggered from the top to the bottom along the horizontal run of the deck ledger.

Figure 20: Lag Screw Requirements

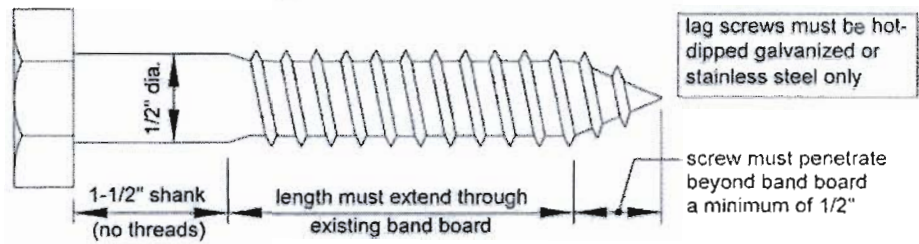

Lag screw installation requirements: Each lag screw shall have pilot holes drilled as follows: 1) Drill a 1/2" diameter hole in the ledger board, 2) Drill a 5/16" diameter hole into the band board of the existing house. **DO NOT DRILL A 1/2" DIAMETER HOLE INTO THE BAND BOARD.**

The threaded portion of the lag screw shall be inserted into the pilot hole by turning. **DO NOT DRIVE LAG SCREWS WITH A HAMMER.** Use soap or a wood-compatible lubricant as required to facilitate tightening. Each lag screw shall be thoroughly tightened (snug but not over-tightened to avoid wood damage).

FREE-STANDING DECKS

Decks which are free-standing do not utilize the exterior wall of the existing house to support vertical loads (see Figure 21); instead, an additional beam with posts is provided at or within L/4 of the existing house. THE ASSOCIATED DECK POST FOOTINGS SHALL BE PLACED AT THE SAME ELEVATION AS THE

EXISTING HOUSE FOOTING (see Figure 2 and Figure 12). For houses with basements, a cylindrical footing (caisson) is recommended to minimize required excavation at the basement wall. Beam size is determined by Table 3.

Figure 21: Free-Standing Deck

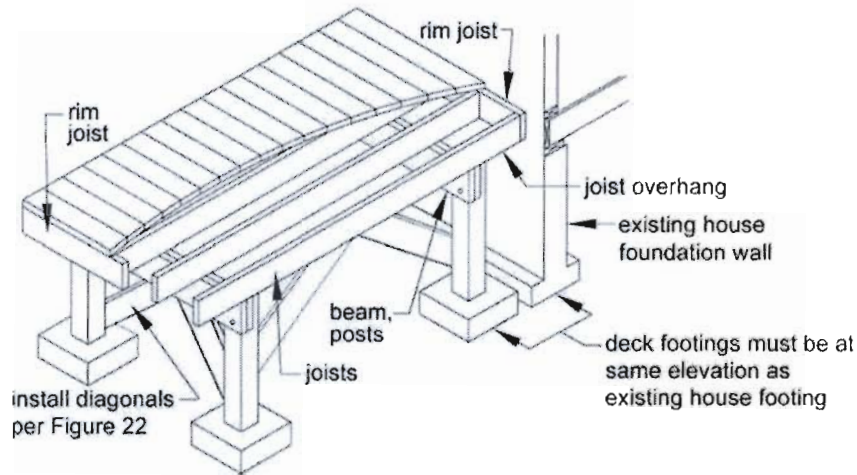

DECK STABILITY

Decks greater than 2 feet above grade shall be provided with diagonal bracing.

Figure 22: Diagonal Bracing Requirements

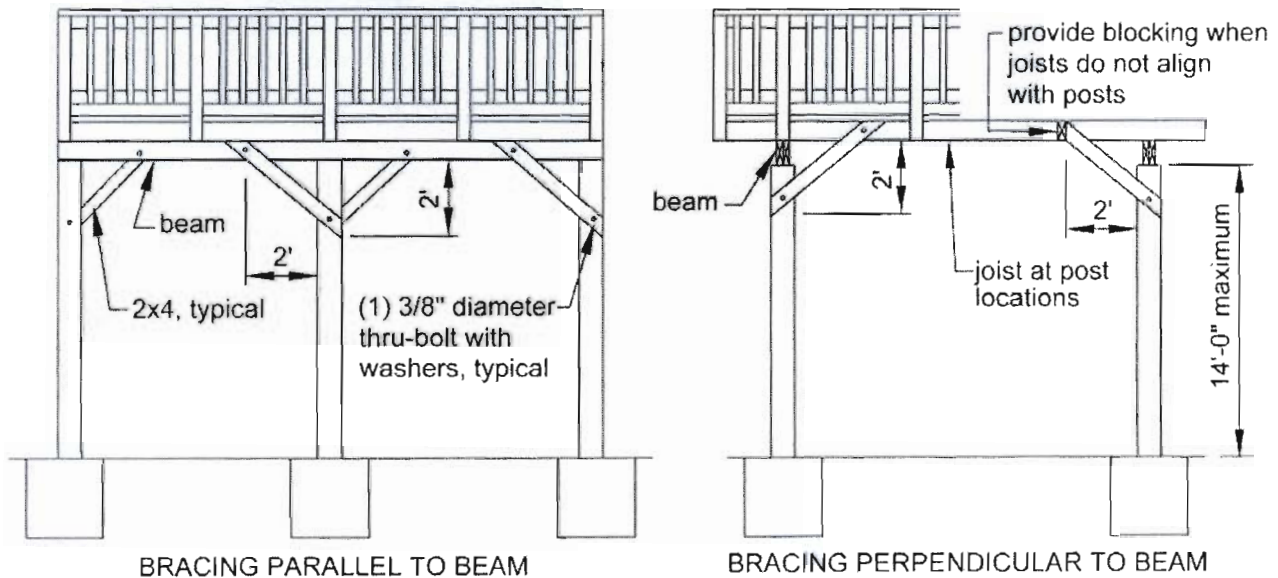

Diagonal Bracing: Provide diagonal bracing both parallel and perpendicular to the beam at each post as shown in Figure 22. When parallel to the beam, the bracing shall be bolted to the post at one end and beam at the other. When perpendicular to the beam, the bracing shall be bolted to the post at one end and a joist or blocking between joists at the other. When a joist does not align with the bracing location, provide blocking between the next adjacent joists. Decks attached to the house do not require diagonal bracing perpendicular to the house.

Attachment to House: Attach the deck rim joist to the existing house exterior wall as shown in Figure 23 for a

free-standing deck or attach the deck ledger to the house as shown in Figures 14, 15, or 16. The wall must be sheathed with minimum $\frac{3}{8}$ " wood structural panel sheathing. Use lag screws or thru-bolts when fastening to an existing band joist or wall stud; use expansion anchors or epoxy anchors when fastening to concrete or masonry. **DO NOT ATTACH TO BRICK VENEERS. VERIFY THIS CONDITION IN THE FIELD PRIOR TO UTILIZING THIS METHOD.** Fasteners shall be 16" on center and staggered in 2 rows for free-standing decks. Flashing over the rim joist is required and must be installed in accordance with the flashing provisions in the LEDGER ATTACHMENT REQUIREMENTS.

Figure 23: Attachment of Free-Standing Deck to House for Deck Stability

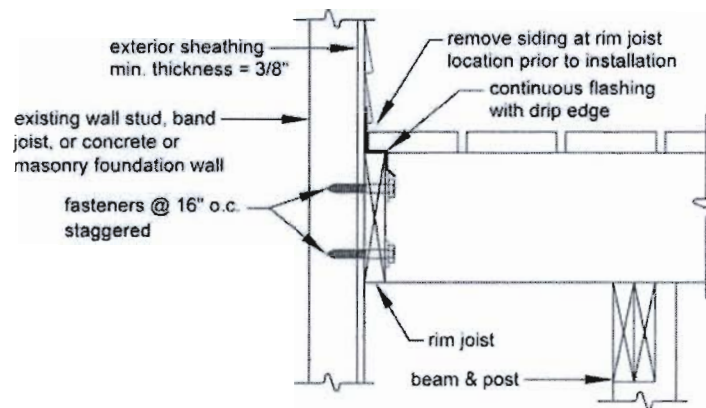

GUARD REQUIREMENTS

All decks greater than 30" above grade are required to have a guard [R312.1] - one example is shown in Figure 24. Other methods and materials may be used for guard construction when approved by the authority having jurisdiction.

Figure 24: Example Guard Detail

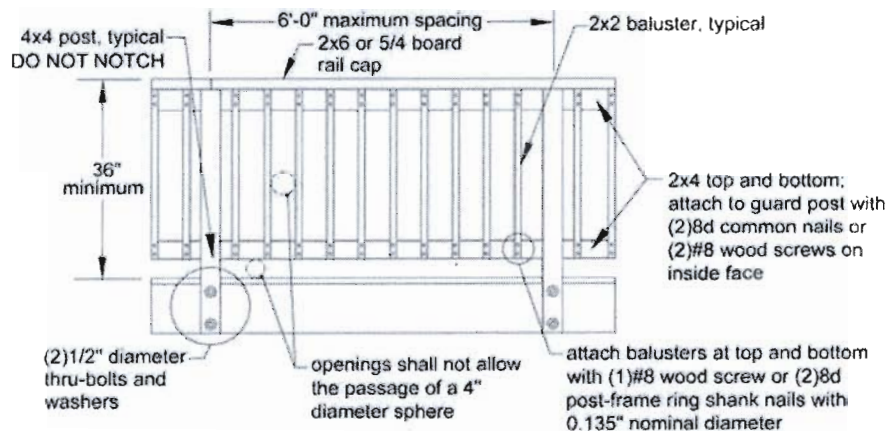

GUARD POST ATTACHMENTS

Deck guard posts shall be a minimum 4x4 (nominal) No.2 or higher grade (for species listed in Table 1) with an adjusted bending design value not less than 1,050 psi.

GUARD POST TO OUTSIDE JOIST: Guard posts for guards which run parallel to the deck joists shall be attached to the outside joist per Figure 25.

Figure 25: Guard Post to Outside Joist Example

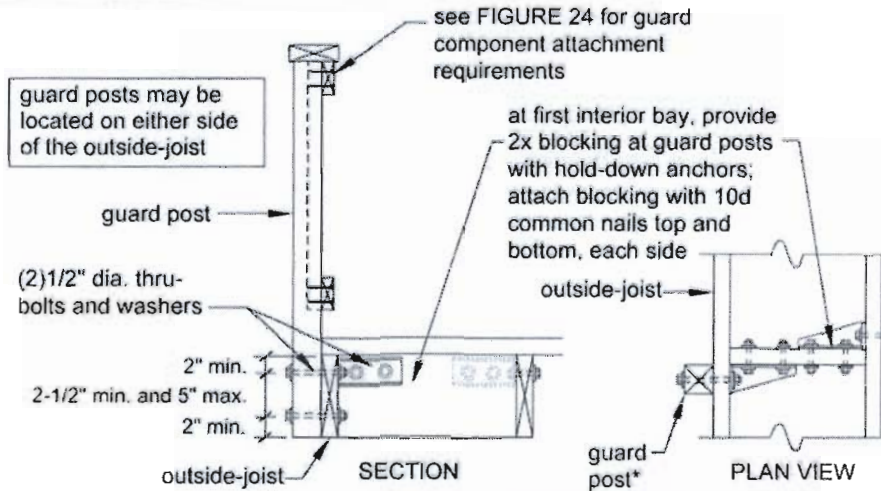

*guard posts can be installed as shown in Figure 26 (between joists) if blocking is installed as shown above within 12" of each side of the post

GUARD POST TO RIM JOIST: Guard posts for guards that run perpendicular to the deck joists shall be attached to the rim joist in accordance with Figure 26. As shown in Figure 26, hold-down anchors must be installed to attach the guard post and rim joist to the

deck joists. There shall be a minimum of two 1/2" diameter bolts at the hold-down anchors' attachment to the joist. Only hold-down anchor models meeting these minimum requirements shall be used.

Figure 26: Guard Post to Rim Joist Example

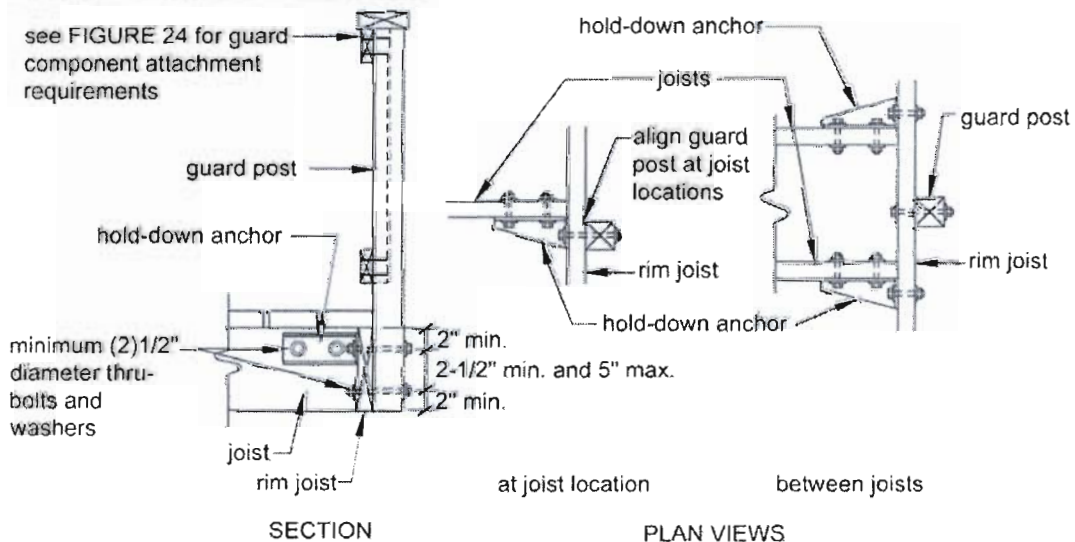

STAIR REQUIREMENTS

Stairs, stair stringers, and stair guards shall meet the requirements shown in Figure 27 through Figure 34 and Table 6 except where amended by the local jurisdiction. All stringers shall be a minimum of 2x12. Stair stringers shall not span more than the dimensions shown in Figure 28. If the stringer span exceeds these dimensions, then a 4x4 post may be provided to support the stringer and shorten its span length. The 4x4 post shall be notched and bolted to the stringer with (2) 1/2" diameter through-bolts with washers per Figure 8. The post shall be centered on a 12" diameter or 10" square, 6" thick footing. The footing shall be constructed as shown in Figure 34 and attached to the post as shown in Figure 12. An intermediate landing may also be provided to shorten

the stringer span (see provisions below). If the total vertical height of a stairway exceeds 12'-0", then an intermediate landing shall be required. All intermediate stair landings must be designed and constructed as a free-standing deck using the details in this document. Stairs shall be a minimum of 36" in width as shown in Figure 33 [R311.5]. If only cut stringers are used, a minimum of three are required. For stairs greater than 36" in width, a combination of cut and solid stringers can be used, but shall be placed at a maximum spacing of 18" on center (see Figure 29). The width of each landing shall not be less than the width of the stairway served. Every landing shall have a minimum dimension of 36" measured in the direction of travel and no less than the width of the stairway served [R311.5].

Figure 27: Tread and Riser Detail

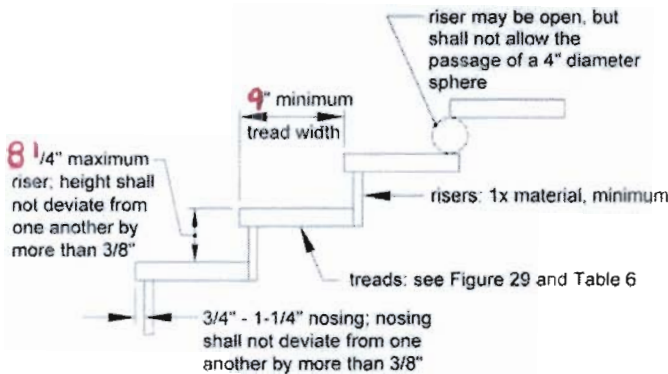

Figure 28: Stair Stringer Requirements

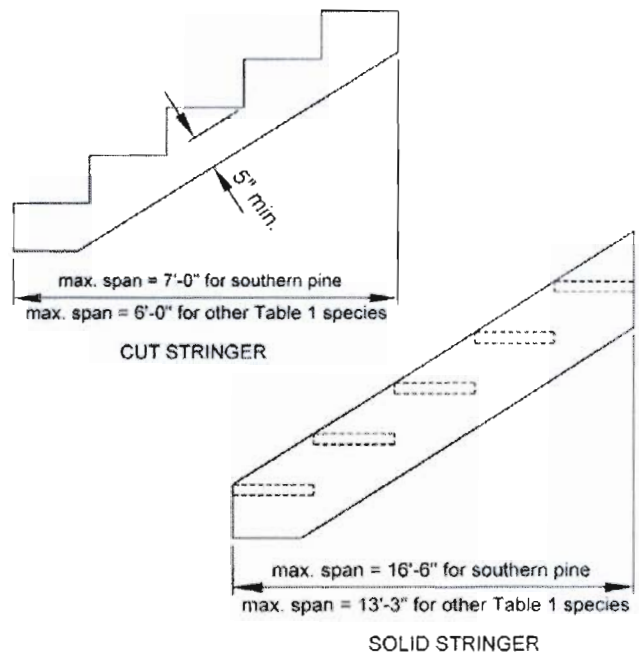

Figure 29: Tread Connection Requirements

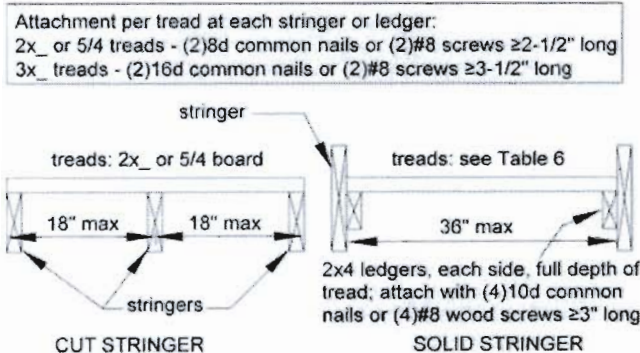

Table 6: Minimum Tread Size for Cut and Solid Stringers¹

Species	Cut Stringer	Solid Stringer
Southern Pine	2x4 or 5/4	2x6
Douglas Fir Larch, Hem-Fir, SPF ²	2x4 or 5/4	2x8 or 3x4
Redwood, Western Cedars, Ponderosa Pine ³ , Red Pine ³	2x4 or 5/4	2x10 or 3x4

1. Assumes 300 lb concentrated load, L/288 deflection limit, No. 2 grade, and wet service conditions.
 2. Incising assumed for refractory species including Douglas fir-larch, hem-fir, and spruce-pine-fir.
 3. Design values based on northern species with no incising assumed.

Figure 30: Stair Guard Requirements

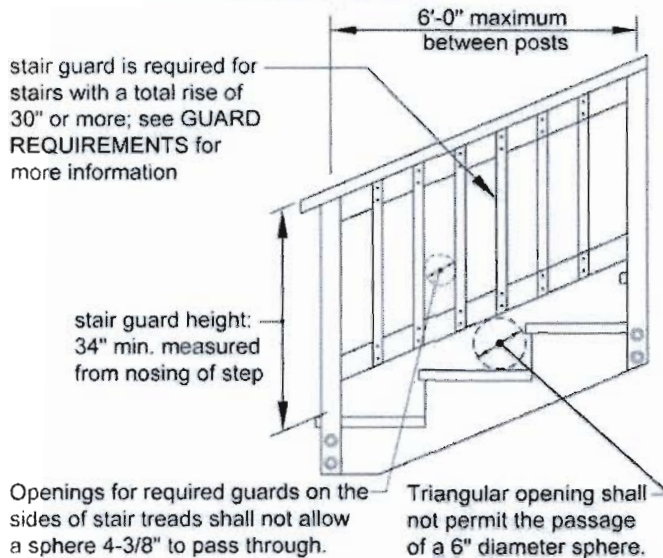
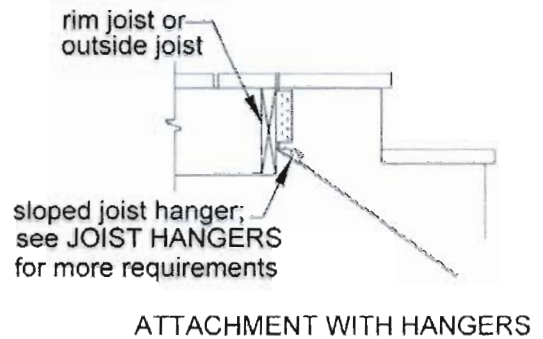

Figure 31: Stair Stringer Attachment Detail



STAIR HANDRAIL REQUIREMENTS

All stairs with 4 or more risers shall have a handrail on at least one side (see Figure 32A) [R311.5.6]. The handrail height measured vertically from the sloped plane adjoining the tread nosing shall be not less than 34 inches and not more than 38 inches (see Figure 30) [R311.5.6.1]. Handrails shall be graspable and shall be composed of decay-resistant and/or corrosion resistant material. Handrails shall be Type I, Type II, or provide equivalent graspability (see Figure 32B). Type I shall

have a perimeter dimension of at least 4" and not greater than 6-1/4". Type II rails with a perimeter greater than 6-1/4" shall provide a graspable finger recess area on both sides of the profile [R311.5.6.3]. All shapes shall have a smooth surface with no sharp corners. Handrails shall run continuously from a point directly over the lowest riser to a point directly over the highest riser and shall return to the guard at each end (see Figure 33). Handrails may be interrupted by guard posts at a turn in the stair [R311.5.6.2].

Figure 32A: Handrail Mounting Examples

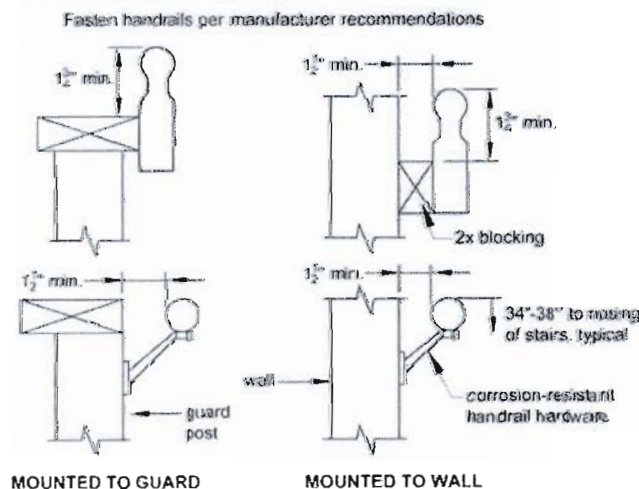
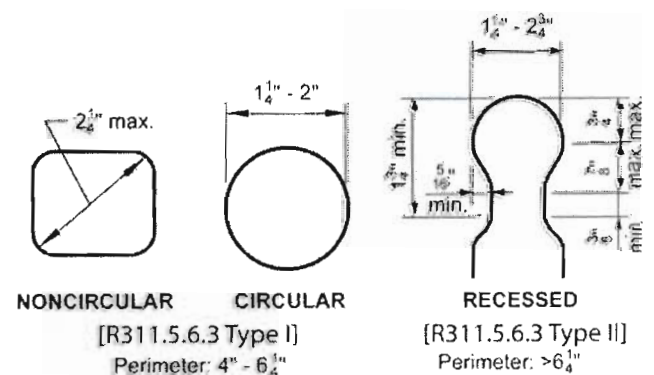

Figure 32B: Handrail Grip Size



STAIR FOOTING REQUIREMENTS [R403]

Where the stairway meets grade, attach the stringers to the stair guard posts as shown in Figure 34. Posts shall bear on footings. All footings shall bear on solid ground and shall be placed at least 12 inches below the undisturbed ground surface or below the frost line, whichever is deeper (see Figure 34). Stringers shall not bear on new or existing concrete pads or patios that are not founded below this depth. When guards are not required (see GUARD REQUIREMENTS), posts may terminate below the bottom tread elevation.

STAIR LIGHTING REQUIREMENTS [R303.6]

Stairways shall have a light source located at the top landing such that all stairs and landings are illuminated. The light switch shall be operated from inside the house. However, motion detected or timed switches are acceptable.

Figure 33: Miscellaneous Stair Requirements

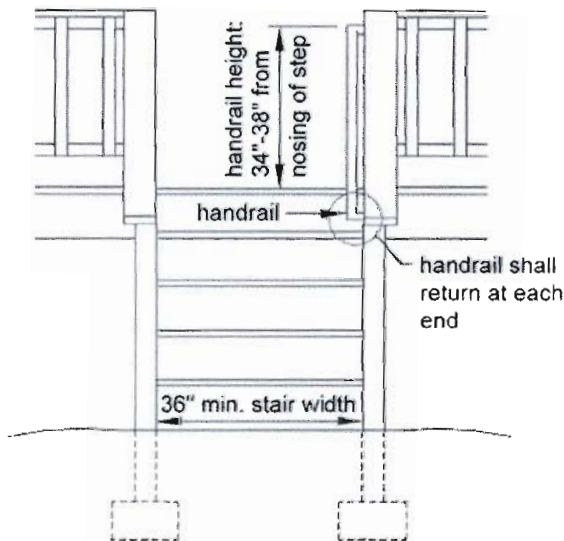
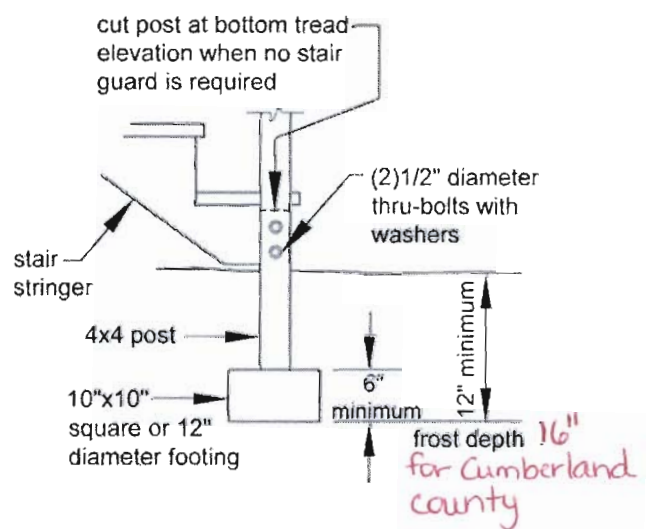

Figure 34: Stair Footing Detail



FRAMING AT CHIMNEY OR BAY WINDOW

All members at a chimney or bay window shall be framed in accordance with Figure 35. Headers may span a maximum of 6'-0". When a chimney or bay window is wider than 6'-0", one or more 6x6 posts may be added to

reduce header spans to less than 6'-0". In such cases, the post footing must meet the requirements in the FOOTINGS section. Headers with a span length greater than 6'-0" require a plan submission.

Figure 35: Detail for Framing Around a Chimney or Bay Window

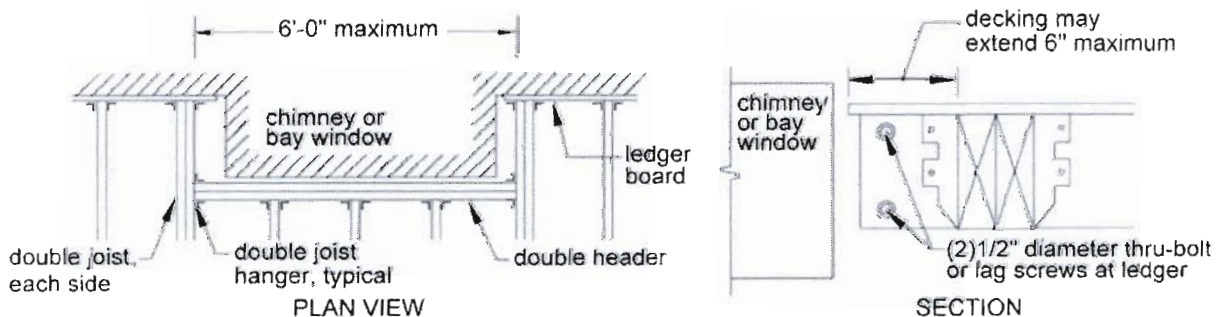

AF & PA[®]AMERICAN
WOOD
COUNCIL*Engineered and Traditional Wood Products*

It is intended that this document be used in conjunction with competent design, accurate fabrication, and adequate supervision of construction. While every effort has been made to insure the accuracy of the information presented, the American Forest & Paper Association and its members do not assume responsibility for errors or omissions in the document, nor for designs, plans, or construction prepared from it. Those using this document assume all liability arising from its use.

Copyright © 2007, 2008
American Forest & Paper Association, Inc.

05-08